

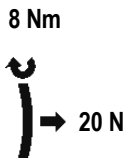

Maniglie estruse in alluminio con tenditore integrato ST400 Aluminium extrusions for handles with integrated adjuster ST400

DENSITA' LINEARE
ST401 670 g/m , ST402 740 g/m
ST403 90 g/m , ST404 360 g/m
LUNGHEZZA: MIN 1200 MAX 2800

LINEAR DENSITY
ST401 670 g/m , ST402 740 g/m
ST403 90 g/m , ST404 360 g/m
LENGTH : MIN. 1200 MAX. 2800



test ST402 lunghezza 2590
ST 402 length test 2590

ACCESSORI PER ESTRUSI
ACCESSORIES FOR ALUMINUM

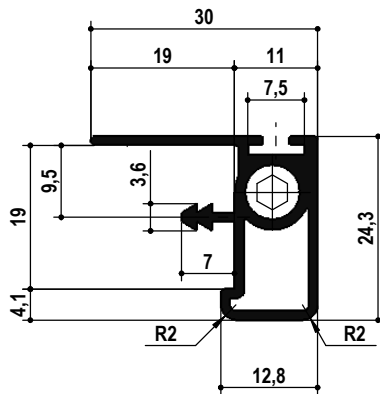

ST401

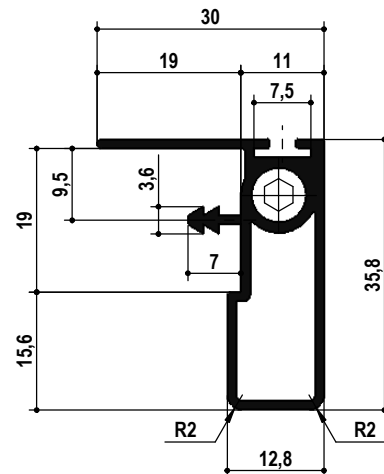

ST402

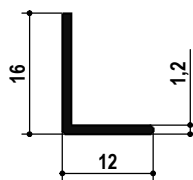

ST403

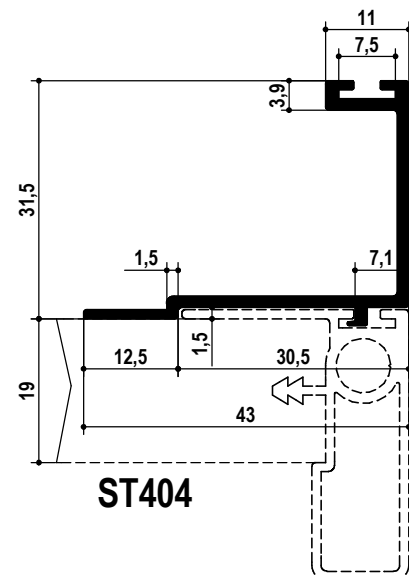

ST404

4
Estrusi all.
Extruded alu.