

# PERMANENT SET FITTING INSTRUCTIONS

2 x PH 1240 = PERMANENT HOUSING  
1 x PC 1240 = PERMANENT CONNECTOR

## Milling

- (i) Plunge Depth: 12.7mm (min) - 13.1mm (max)
- (ii) Travel Distance: 40mm

## CNC Recommended Speeds

Plunge: 2.5 Metres  
Travel: 5 Metres - 7.5 Metres  
Rotation: 18,000 Revolutions

*Speed applies to MDF / Chipboard / Solidwoods*

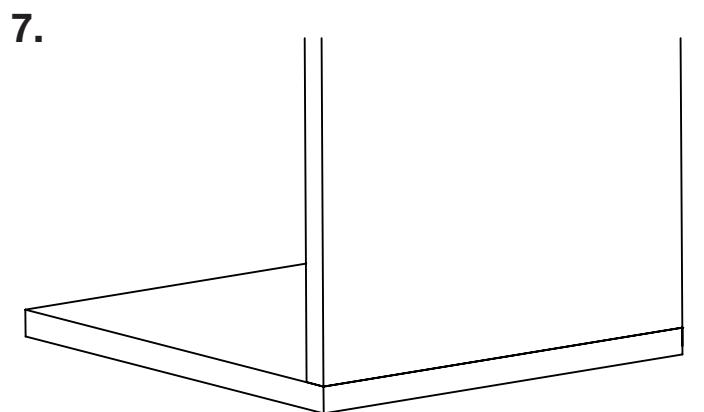
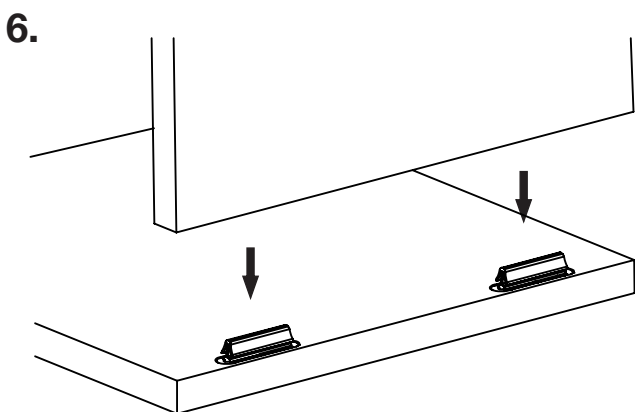
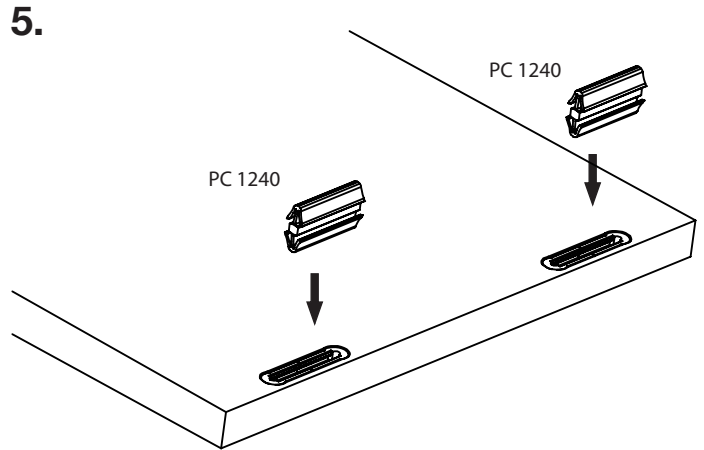
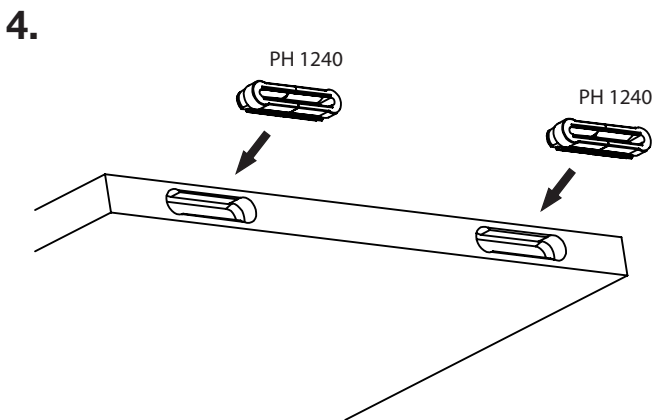
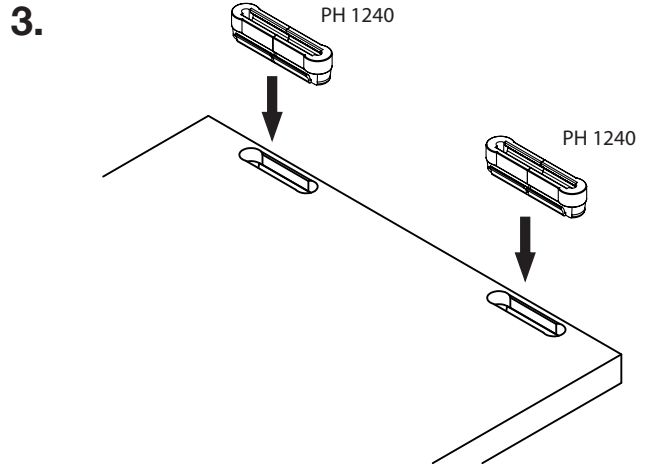
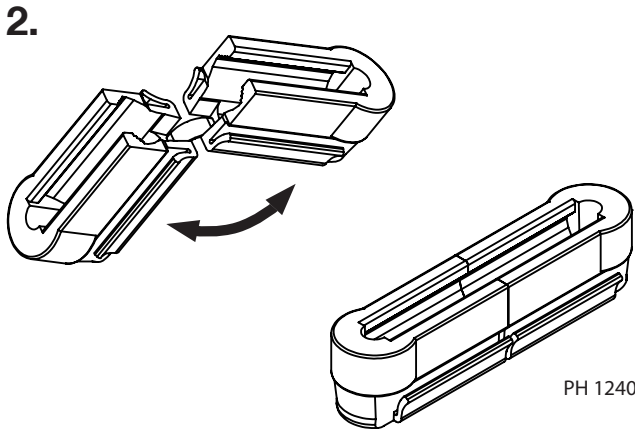
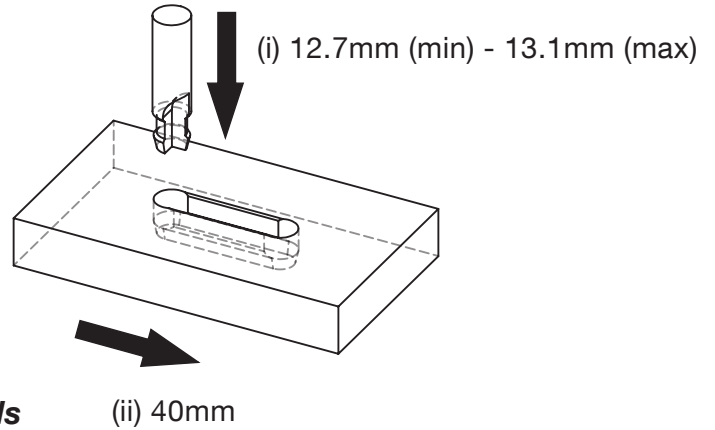

# RELEASABLE SET FITTING INSTRUCTIONS

- 1 x RH 1240 = RELEASABLE HOUSING
- 1 x RC 1240 = RELEASABLE CONNECTOR
- 1 x PH 1240 = PERMANENT HOUSING

## Milling

- (i) Plunge Depth: 12.7mm (min) - 13.1mm (max)
- (ii) Travel Distance: 40mm

## CNC Recommended Speeds

- Plunge: 2.5 Metres
- Travel: 5 Metres - 7.5 Metres
- Rotation: 18,000 Revolutions

*Speed applies to MDF / Chipboard / Solidwoods*

