

Giunzioni Connecting fittings

GIUNZIONE DELLA SERIE GN400 E' CARATTERIZZATA DALL'ESSERE COMPLETAMENTE A SCOMPARSA UNA VOLTA MONTATA.

FIGURA A: LA PARTICOLARE FORMA INDICATA NELLA FIGURA A GENERA DURANTE L'ASSEMBLAGGIO UNA FORZA DI TRAZIONE TRA RIPIANO E IL MONTANTE.

FIGURA B-C : MOSTRANO LE DUE MODALITA' DI ASSEMBLAGGIO DELLA GN400.

LA PRIMA CON UN MOVIMENTO ORIZZONTALE.
LA SECONDA CON DUE MOVIMENTI, VERTICALE E ORIZZONTALE.

THE GN400 SERIES CONNECTING FITTING IS CHARACTERISED BY BEING COMPLETELY RETRACTABLE ONCE INSTALLED.

FIGURE A: THE SPECIAL SHAPE INDICATED IN FIGURE A GENERATES A TRACTION FORCE BETWEEN THE SHELF AND THE UPRIGHT WHEN ASSEMBLING.

FIGURES B-C: SHOW THE TWO ASSEMBLY METHODS OF THE GN400.
THE FIRST WITH A HORIZONTAL MOVEMENT.
THE SECOND WITH TWO MOVEMENTS, VERTICAL AND HORIZONTAL.

Serie GN400 GN400 Series

figura : A
drawing: A



figura : B
drawing: B



figura : C
drawing: C



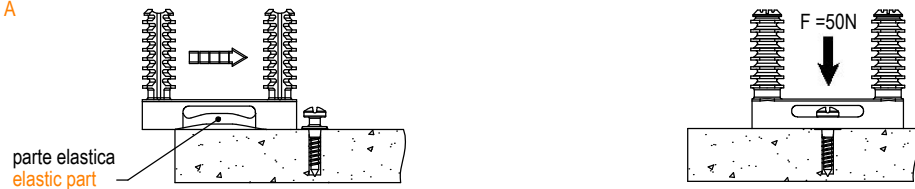

Giunzione tipo GN401-402 GN411-412 per assemblaggio in orizzontale Invisible shelf support type GN401-402 GN411-412 for horizontal assembly

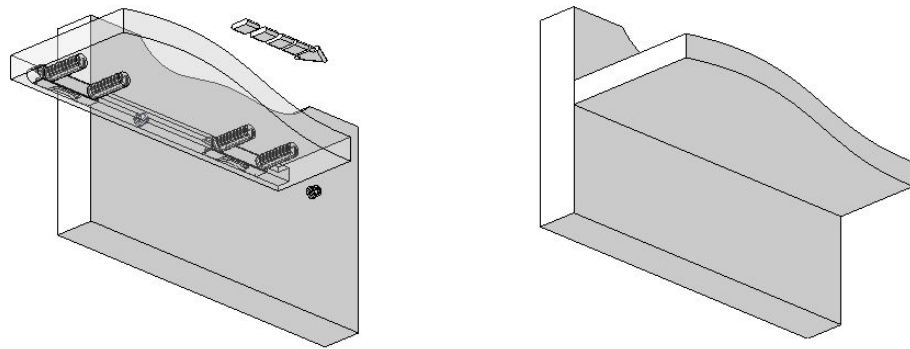
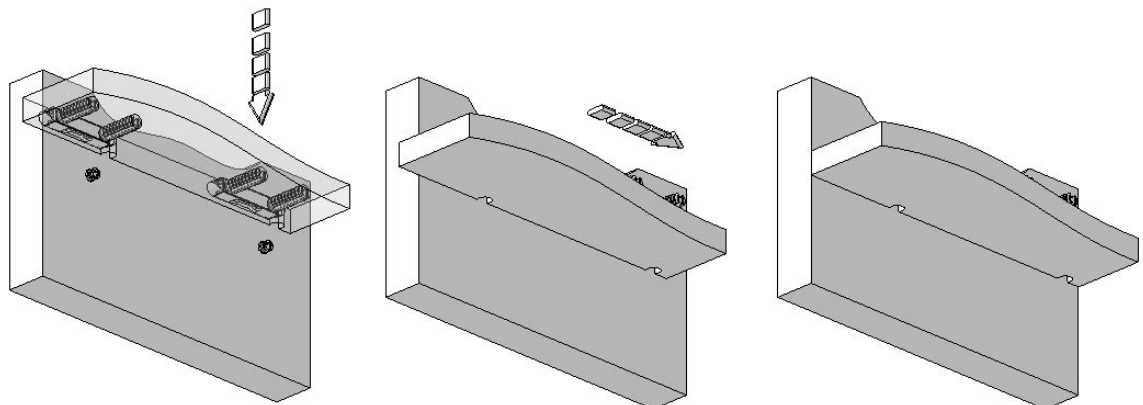
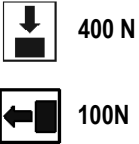

nylon grigio
gray nylon

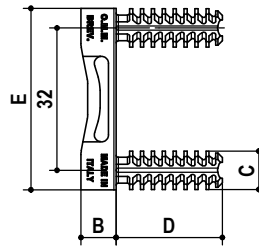
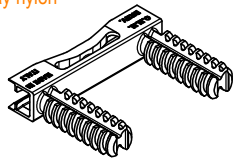

giunzione GN401 - GN411 con asola passante
shelf support GN401 - GN411 through slot

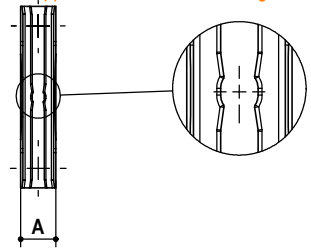

giunzione GN402 - GN412 con fermo
shelf support GN402 - GN412 with stop

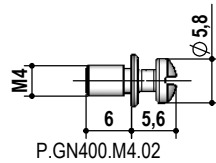
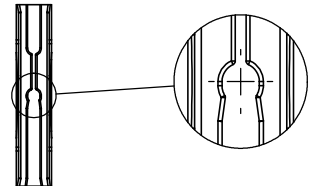

P.GN400.M4.02

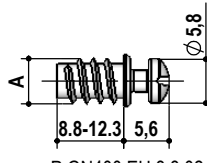

P.GN400.EU.8,8.02
P.GN400.EU.12,3.02

filetto mordente 2.9
chipboard head 2.9

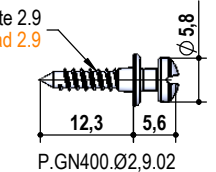

P.GN400.Ø2,9.02

ACCESSORI ACCESSORY



BUSOLE A RICHIESTA
SPECIFICARE DIMENSIONI E TIPO.

BUSHINGS ON REQUEST SPECIFY
SIZE AND TYPE.

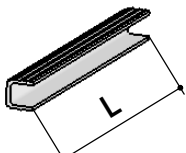

COPERTURA IN PVC
PVC COVER CARTER
GN400.CP."L".55

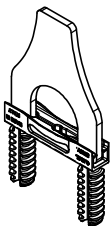

DIMA MONTAGGIO MANUALE
MANUAL MONTAGE TEMPLATE
P.GN400.AT.02

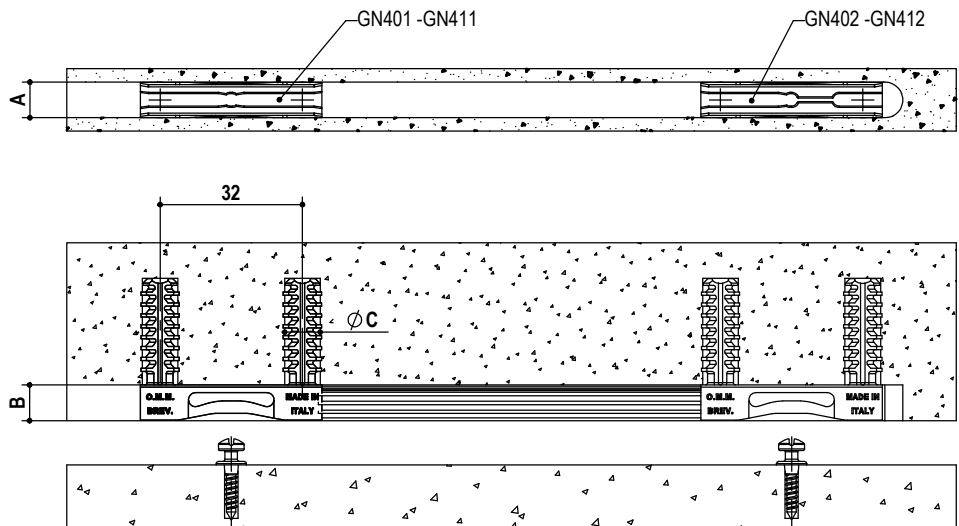

tipo type	misura measure	A	B	C	D	E	finitura finishing
P.GN401.	8x8.	8	8	24	41	55 grigio grey	
P.GN402.	8x8.						
P.GN411.	12x8.	12	12	28	45		
P.GN412.	12x8.						

es./e.g.: P.GN401.8x8.55

Giunzione tipo GN402 GN412 per assemblaggio in verticale

Invisible shelf support type GN402 GN412 for vertical assembly



400 N



100 N

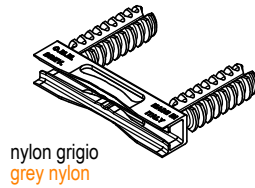

nylon grigio
grey nylon

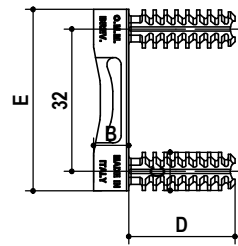

giunzione GN402 con fermo
shelf support whit stop

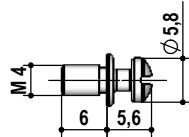
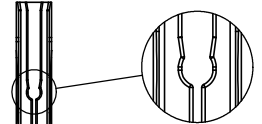

P.GN400.M4.02

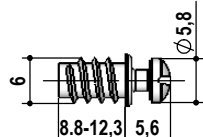

P.GN400.EU.8.8.02
P.GN400.EU.12.3.02

filetto mordente 2.9
chipboard head 2.9

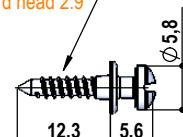

P.GN400.Ø2,9.02

ACCESSORI ACCESSORIES

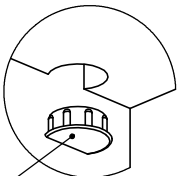

TAPPO SFACCETTATO
PER FORO Ø 8mm.
FACCEDED CAP FOR
8mm HOLE.
Cod. P.T.400.08



BUSSELE A RICHIESTA
SPECIFICARE DIMENSIONI E TIPO

BUSHINGS ON REQUEST SPECIFY
SIZE AND TYPE.

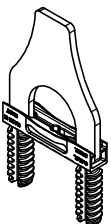

DIMA MONTAGGIO MANUALE
MANUAL MONTAGE TEMPLATE
P.GN400.AT.02

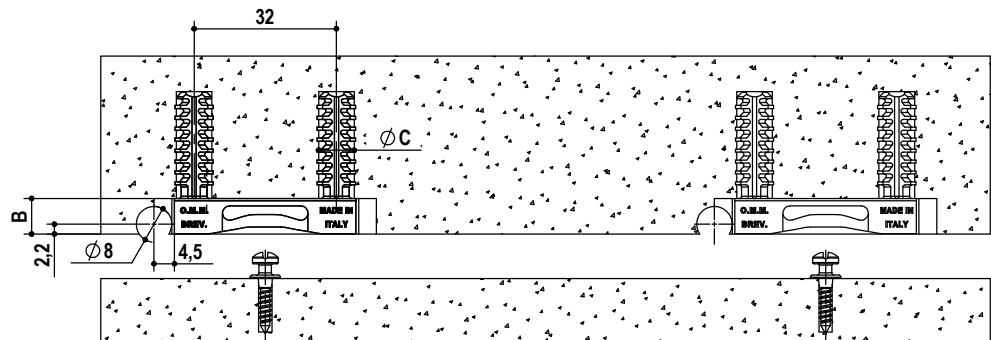
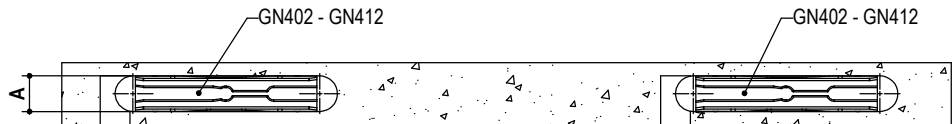

tipo	misura	misura					finitura
type	measure	A	B	C	D	E	finishing
P.GN402.	8x8.	8	8	8	24	41	55 grigio grey
P.GN412.	12x8.	12	12	12	28	45	

es./e.g.: P.GN402.8x8.55